

#### Folding/Forming Sequence

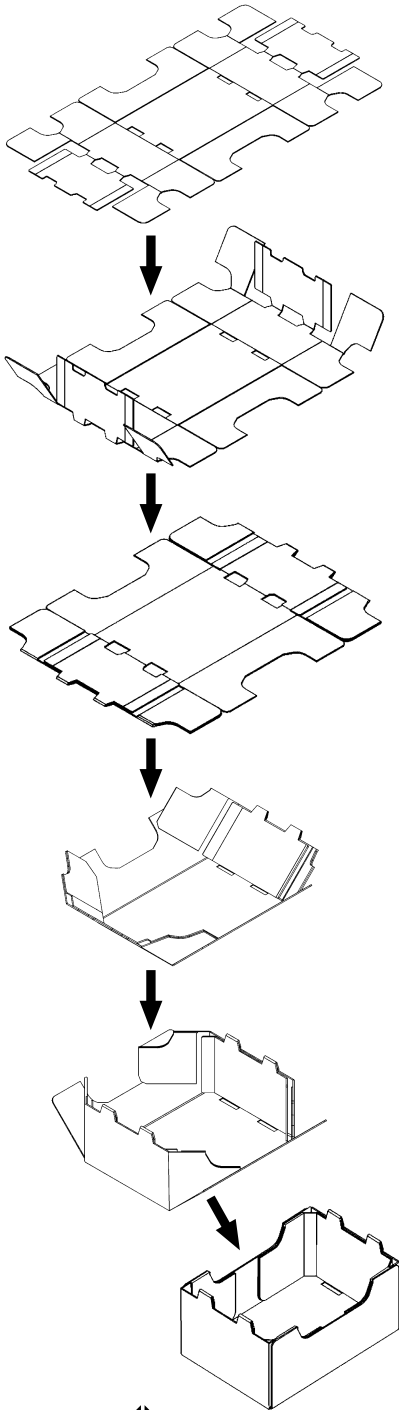

#### The PF129 features:

- **Modular Frame**
- **Variable Frequency Belt Drive**
- **Moen Model M3A Glue System**
- **UL Approved Electrical Control Panel**
- **Vacuum Tray Blank Picking System**
- **24 VDC Machine Control**
- **Touch Screen Controls and Operator Interface**
- **Stainless Steel Paint Finish**

The Moen model PF129-LT Tray Former was designed and built to provide a superior tray forming system for the Common Footprint Tray now in use for fresh fruit produce. The standards for this package were developed by the Fibre Box Association. The common outside dimensions of the tray (length and width) are 23-1/2 x 11-11/16 and stack on the pallet five boxes per tier (5-down). There is also a half size tray, 15-11/16 x 11-11/16, that stacks ten boxes per tier on the pallet (10-down). The depth of the tray varies depending upon the requirements of the product. The standards for stacking tabs and mating slots (for vertical alignment and load stability) have been specified so both tray sizes will fit together on the same pallet load. In addition to common footprint trays, the PF129-LT is capable of forming other laminated end or side wall sizes within its specified capacity.

Based upon these FBA standards, a number of new, innovative tray designs have been developed. The PF129-LT, conceived with this in mind, was engineered with a modular frame so it could be built to accommodate a number of tray styles. In addition to this important element, the PF129-LT is built *Moen Tough* for the rugged environment of packing shed operations. Moen's decades of experience in serving the U.S. fresh fruit and produce community has supplied us with the know-how needed to offer *workhorse* packaging equipment to this industry.

# Laminated Side or End Wall Tray Former

Model PFI29-LT

## Tray Machine Air Consumption per cycle

Air usage per cycle in SCFM	<b>2.075</b>
SCFM with regenerative blower	<b>1.475</b>
SCFM with servo driven mandrel & Moen vacuum	<b>1.437</b>
SCFM with servo driven mandrel & pick & Moen vacuum	<b>1.109</b>
SCFM with all air reduction options	<b>0.509</b>

## Outputs

**2.075**  
**1.475**  
**1.437**  
**1.109**  
**0.509**

## Size Capacity

Maximum Blank Size	<b>47" x 58"</b>
Maximum Box Footprint	<b>29" x 29" x 10-1/2"</b>
Minimum Box Footprint	<b>9" x 12" x 3-1/2"</b>

## Electrical Requirements

<b>Standard</b>	<b>Optional</b>
<b>230 VAC</b>	<b>460 VAC</b>
<b>60 Hz</b>	<b>60 Hz</b>
<b>25 Amps</b>	<b>15 Amps</b>

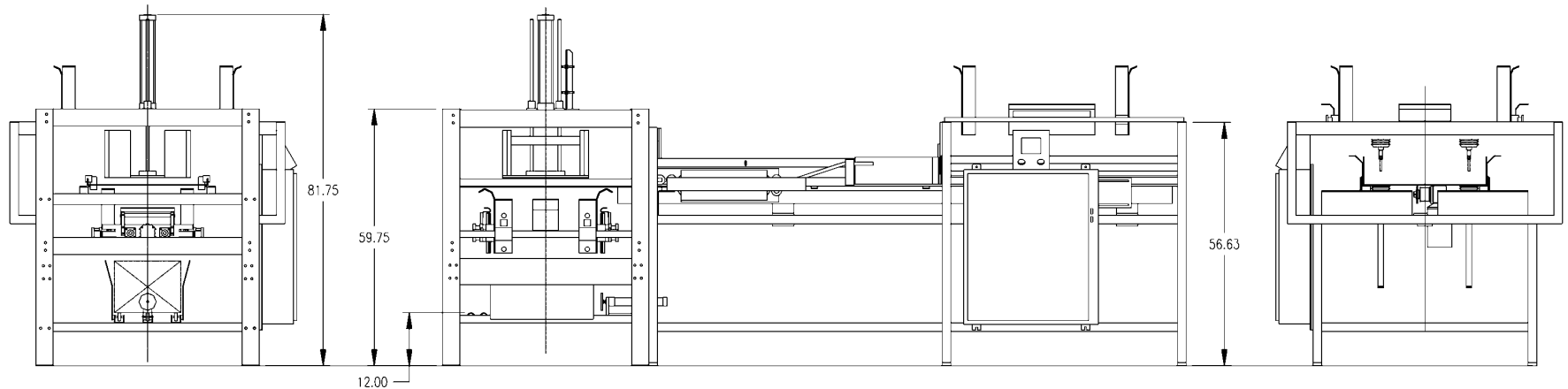
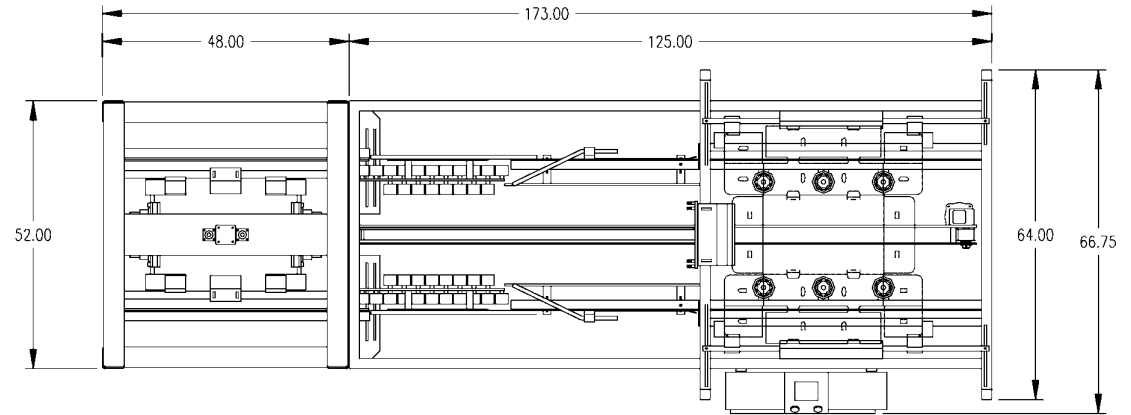

Quality Corrugated Packaging Equipment

**Rate of Production: Up to 35 t.p.m.**

12333 East Los Nietos Road, Santa Fe Springs, CA 90670

(562) 946-6381 ■ FAX (562) 946-3200 ■ Email: sales@moenindustries.com Web Site: www.moenindustries.com

MPFI29-LT/9-22-06r4